



HAL
open science

Border recovery for subband processing of finite-length signals. Application to time-varying filter banks

François Déprez, Olivier Rioul, Pierre Duhamel

► **To cite this version:**

François Déprez, Olivier Rioul, Pierre Duhamel. Border recovery for subband processing of finite-length signals. Application to time-varying filter banks. 1994 IEEE International Conference on Acoustics, Speech, and Signal Processing (ICASSP-94), Apr 1994, Adelaide, Australia. pp.133-136, 10.1109/ICASSP.1994.390072 . hal-03330268

HAL Id: hal-03330268

<https://telecom-paris.hal.science/hal-03330268v1>

Submitted on 9 Aug 2022

HAL is a multi-disciplinary open access archive for the deposit and dissemination of scientific research documents, whether they are published or not. The documents may come from teaching and research institutions in France or abroad, or from public or private research centers.

L'archive ouverte pluridisciplinaire **HAL**, est destinée au dépôt et à la diffusion de documents scientifiques de niveau recherche, publiés ou non, émanant des établissements d'enseignement et de recherche français ou étrangers, des laboratoires publics ou privés.

BORDER RECOVERY FOR SUBBAND PROCESSING OF FINITE-LENGTH SIGNALS. APPLICATION TO TIME-VARYING FILTER BANKS

François Déprez¹

Olivier Riou¹

Pierre Duhamel²

¹CNET Paris B, 38-40 rue du General Leclerc, 92131 Issy-Les-Moulineaux, France

²ENST, Dept. SIG, 46 rue Barrault, 75013 Paris, France

ABSTRACT

In the context of subband processing of finite-length signals using FIR filter banks, a new technique is derived for achieving exact reconstruction when subband signals are truncated to the same number of samples as the original signal. Using a delayed truncation method in the subbands, it is shown that the missing samples can be recovered exactly by inverting small linear systems. Our approach also applies to time-varying filter banks or wavelet transforms where filters are switched between consecutive input blocks.

1. INTRODUCTION

When implementing a perfect reconstruction FIR filter bank for subband coding of signals of finite extent, such as images, the processing of boundary regions give rise to the following problem. Assume, for example, that an input signal X of length N , extended by zeroes outside the interval $(0, N-1)$, is processed using the filter bank depicted in Fig. 1. Subband analysis of X results in a total amount of samples greater than that of the input: The subband signals Y and Z have $N/2 + L/2$ samples each, where L is the length of the filters. This is due to the transients of the filtering process needed for splitting X into different channels. Thus, L extra coefficients near the boundaries have to be coded and transmitted to reconstruct X exactly. This is generally undesirable for compression problems because of the increase of the encoded data, which becomes higher as the number of iterations of the filter bank increases. Also, the size of the subimages become nonstandard. On the other hand, if the number of samples to be encoded is made equal to N by truncation at the borders of Y and Z , some information is apparently lost, which makes boundary distortion in the reconstructed signal unavoidable [4]. The first issue addressed in this paper is to achieve *exact reconstruction* in the presence of truncation to N samples in the channels, i.e. without any increase of the data throughput after processing.

A related problem concerns time-varying filter banks, where filters are switched at some transition location between consecutive input blocks. Such techniques have received increased attention recently [1, 5, 7] because they can be used to exploit the time-varying nature of the signal if they are dynamically adapted to match its short-term properties over time. A variation of this technique applies to time-varying "wavelet" tree structures [3, 7]. The second issue considered in this paper is to achieve exact reconstruction in this context, in such a way that the sampling rate is preserved in the subbands at the transitions. Our approach readily applies to this problem when each block is processed independently of its neighbors. Similar ideas are also developed in the case

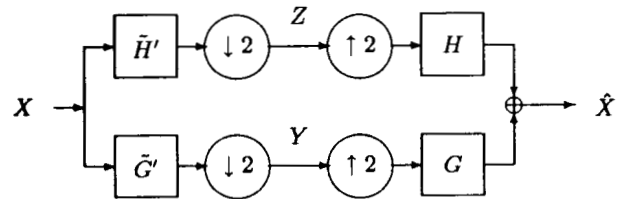

Figure 1. A two-band perfect reconstruction FIR filter bank. All filters are assumed to be of even length L . The tilde symbol denotes time reversal: this convention on the analysis filters will simplify subsequent formulations. Output \hat{X} is equal to X delayed by $L-1$ samples.

of interrelated blocks.

The originality of our approach is the use of a *delayed truncation* method in the subbands. The main idea behind the various techniques described here is the following: After truncation, it is possible to recover the missing samples of the subband signals *exactly* (by matrix inversion.) This has several straightforward, but interesting consequences:

As opposed to techniques derived in [3], after recovery, the synthesis bank is unchanged compared to the naive situation where extra coefficients are transmitted without truncation. Therefore, there is no need to carry out a specific design procedure for boundary or transition filters as was done in previous works [3, 5, 7]. Also, *exact reconstruction* is achieved in all cases (as opposed to the technique proposed in [5]). Finally, like in [3], specific properties of the transform, such as orthogonality, can still be exploited for coding purposes after the missing samples have been recovered.

A similar approach was investigated by de Queiroz in [6] in the restrictive case of extension at the edges of the input signal. We show that the delayed truncation method can be used to simplify matters considerably in many other contexts.

This paper is organized as follows. First, we present a simple example for which the philosophy of our approach becomes clear. Our method is then extended to the case where different types of border extensions are made on the signal. Next, we present the iterated formulation of our method which applies to wavelet transforms and wavelet packets. Finally, we apply previous ideas to time-varying filter banks.

2. A SIMPLE EXAMPLE

We consider the filter bank of Fig. 1, applied to a signal X of finite length N . We assume N and L even: This approach can be easily adapted to odd values of N and L . Our delayed truncation method consists of keeping the last $N/2$ samples of Y and the first $N/2$ samples of Z , which amounts to keeping the same quantity of data as in the original signal.

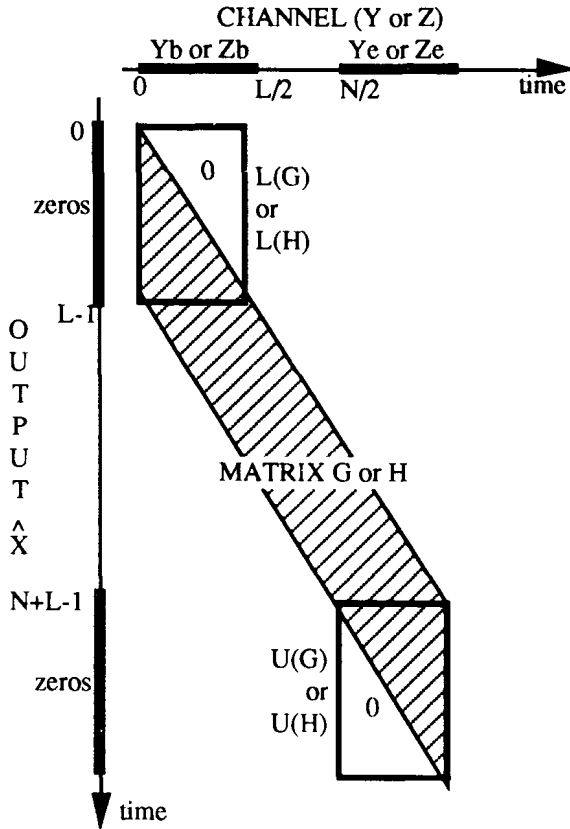

Figure 2. Schematic matrix description of the synthesis bank, meant to represent the formula $\hat{X} = \mathbf{G}Y + \mathbf{H}Z$, where \mathbf{G} and \mathbf{H} are interpolation+convolution matrices corresponding to the synthesis filters.

As shown below, after delayed truncation, there is still enough information available in the transmitted signal to recover perfectly the original input X . This is done by recovering the samples that have been discarded, and then proceed as if they were transmitted.

Throughout the paper we use the following notations at the beginning and end of the block: $Y_b = (y_0, \dots, y_{L/2-1})^t$ and $Y_e = (y_{N/2}, \dots, y_{N/2+L/2-1})^t$ are column vectors representing the first and last $L/2$ samples in Y . Similarly we define Z_b and Z_e for subband signal Z . Our problem therefore reduces to recover Y_b and Z_e from the other samples of Y and Z . Fig. 2 illustrates the matrix representation of the convolution relations at the borders during synthesis. The "border" matrices of size $(L-1) \times L/2$ are $\mathbf{L}(G)$ and $\mathbf{L}(H)$ at the beginning of the block, and $\mathbf{U}(G)$ and $\mathbf{U}(H)$ at the end of the block, where

$$\mathbf{L}(G) = \begin{pmatrix} g_0 & 0 & \dots & 0 \\ g_1 & 0 & \dots & 0 \\ g_2 & g_0 & 0 & \dots & 0 \\ g_3 & g_1 & 0 & \dots & \vdots \\ \vdots & & \ddots & & 0 \\ g_{L-2} & g_{L-4} & \dots & g_2 & g_0 \end{pmatrix} \quad (1)$$

and $\mathbf{U}(G)$ is obtained from $\mathbf{L}(G)$ by reversing lines, columns, and filter coefficients.

The border recovery procedure can be carried out independently at the beginning and at the end of the block by writing the synthesis equations at both sides. We assume $L-1 \leq N$ to avoid interference between the beginning and end of block. Since the filter bank allows exact reconstruction when no truncation occurs, the transients of the filtering process in the analysis and synthesis must cancel, and we have (see Fig. 2)

$$\mathbf{L}(G)Y_b + \mathbf{L}(H)Z_b = 0 \text{ and } \mathbf{U}(G)Y_e + \mathbf{U}(H)Z_e = 0 \quad (2)$$

We obtain an over-determined linear system of equations, which is clearly full-rank, and since we must have a unique solution, half of the equations are redundant. Selecting one every other line in the system results in a lower or upper triangular matrix to be inverted, which is easily done by substitution. One possible choice at the beginning of the block is

$$Y_b = -\mathbf{L}_G^{-1} \mathbf{L}_H Z_b \quad (3)$$

where $\mathbf{L}_G = ((g_{2i-2j}))_{i,j}$ is a lower triangular Toeplitz matrix, and similarly for \mathbf{L}_H . Other choices are possible (e.g. involving odd-indexed terms) and would lead to a different sensitivity to quantization, depending of the values of the filter coefficients. Similarly, Z_e is recovered from Y_e by upper triangular matrix inversion. In this case, a delay is introduced which can be compensated for in the analysis.

3. OTHER TYPES OF BOUNDARY EXTENSION

So far we assumed that the signal is padded with zeroes outside its support, but our method can also be generalized to other types of boundary extension, which can be of interest for image coding [4].

Circular extension, where signal X is periodic of period N , is a well-known method for achieving perfect reconstruction while also transmitting only N samples. However, it creates artificial discontinuities in the extended signal, making it harder to encode [4]. The following extensions are generally preferred as they make the signal continuous at the edges.

The first one consists of replicating the boundary values at both ends in the signal. The generalization of the delayed truncation method is easy in this case: Consider for example the recovery of Y_b from Z_b . Equation (2) is the same except for a nonzero right-hand side in which the only additional unknown is the boundary value x_0 . This value can be easily determined using the analysis equations which gives $x_0 = x_0 \sum_n h'_n$ as the boundary value of Z . If the sum of the filter coefficients is $\neq 0$, especially if H' is chosen to be the low-pass analysis filter, x_0 is determined easily (otherwise, a trick can be used to recover x_0 [2]). Once x_0 is determined, the synthesis equation can be solved for Y_b by inverting a triangular matrix as in section 2.

The second and most popular extension makes the signal symmetric around the boundaries. Exact reconstruction at the borders is easily achieved under the constraint that filters have linear phase [6]. However, it is desirable to solve this problem for filters having arbitrary nonlinear phase, if e.g. orthogonality of the system is required. In this case an answer was given by de Queiroz [6], also based on linear system inversion but whose matrix is not necessarily full-rank. Using our delayed truncation approach, we can show [2] that the missing samples can be recovered by inversion of a full-rank (non-triangular) square matrix. However, the derivation is a little involved. Details can be found in [2].

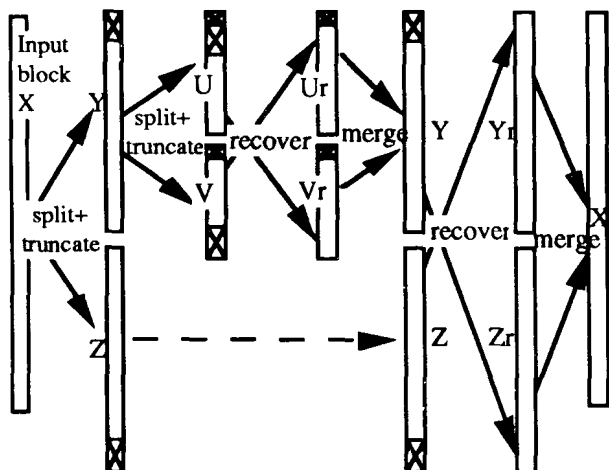

Figure 3. Two-stage analysis/synthesis system with border recovery. Truncation is indicated by crosses and subscripts "r" means "recovered."

4. ITERATED FILTER BANKS

In this section we extend our method to iterated filter banks such as the ones used in discrete wavelet transforms. A straightforward extension, of course, consists of iterating the subband decomposition directly on the truncated subband signals Y or Z . However, a major drawback is that the recovered subband signals after the second stage of decomposition are not the same as what would be obtained without truncation. Although the system allows perfect reconstruction, the signal characteristics are affected near the boundaries, which may be undesirable in coding systems.

In order to obtain, after truncation and recovery of the missing samples, the 'true' subband signals, it is necessary to derive a more adequate generalization of the procedure described in section 2 (we consider that the input X is padded with zeros outside its support for convenience). This is illustrated in Fig. 3 in the case of one iteration on one branch of the two-band filter bank.

The first decomposition is the same as in section 2: The first $L/2$ samples of Y and the last $L/2$ samples of Z are discarded and recovered at the end. After Y is split into signals U and V , Fig. 3 shows that the first $L/4$ samples in U and V are missing. The total length of U and V would be $(N/2 + L/2)/2 + L/2 = N/4 + 3L/4$ if no truncation were present, hence there remain $N/4 + L/2$ samples in each vector. Now one can still discard $L/2$ samples in U and V as shown in Fig. 3. This yields the desired result, i.e., the total number of samples transmitted through signals Z , U and V is $N/2 + N/4 + N/4 = N$. The recovery procedure for U and V then works pretty much as explained in section 2.

This method can be easily extended for arbitrary decompositions of the filter bank, provided that the low-pass and high-pass branches are not iterated at the same time. This is the case for wavelet transforms and for a large class of wavelet packets.

Note that at each stage j of the decomposition, we assume that $L - 1 \leq N/2^{j-1}$ so that the beginning and end of block are not overlapping. This requirement is satisfied in practical systems as long as the subband decomposition is stopped when the impulse responses become as large as the signal.

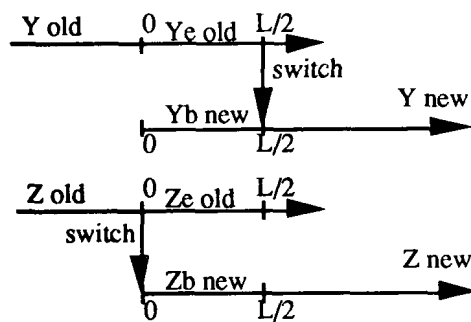

Figure 4. Description of the transition period near time $n = 0$ when the system is switched from the "old" filter bank to the "new" one. To simplify, we assume all filters have the same length L .

5. TIME-VARYING FILTER BANKS

One possible way for the filter bank of Fig. 1 to be time-varying is to switch the filters from the set $(G'_{old}, H'_{old}, G_{old}, H_{old})$ to the set $(G'_{new}, H'_{new}, G_{new}, H_{new})$ at some transition location (say at time $n = 0$) between consecutive input blocks X_{old} and X_{new} . The problem addressed in this section is to achieve perfect reconstruction in this context without increasing the throughput rate.

An easy and acceptable solution to this problem consists of using the techniques described above for each block independently of its neighbors. In fact, this procedure can be rewritten [2] in a form that parallels the approach of Nayebi *et al.* [5], where transition filters vary near the transition locations. Notice that the filters as well as the structure and number of bands in the system can be changed from one block to the next, since each block is processed independently. Hence, this is applicable to wavelet packets that generate arbitrary tilings of the time-frequency plane [3]. Moreover, the resulting procedure is very simple to carry out as compared to [3, 7] since no design procedure is needed. However, it is based on somewhat artificial extensions on the boundaries of each block, and intercorrelation between blocks is not exploited, which can be a drawback for compression problems.

In the following we present an improved procedure that takes block intercorrelation into account. We consider a non-iterated filter bank of Fig. 1 for convenience. We wish to recover missing samples at the transition by inverting a linear system in which information about both sides of the transition is present. In keeping with the philosophy of our approach, we use a delayed blocking in the subbands illustrated in Fig. 4. In the channels, switching from Y_{old} to Y_{new} is made at time $n = 0$, while switching from Z_{old} to Z_{new} is made at time $n = L/2$. As a result, the vectors Y_b^{new} and Z_e^{old} are discarded as shown in Fig. 4, and have to be recovered to reconstruct the input exactly at the transition.

Fig. 5 illustrates the transition using the same schematic matrix description as in Fig. 2. The "transition" matrices in the synthesis part are $L(G_{old})$, $L(H_{old})$, $U(G_{new})$, $U(H_{new})$ as defined in section 2 (see (1)). In the analysis, it is easily seen that the transition matrices are in fact transposed forms of $L(\cdot)$ and $U(\cdot)$ (with the time-reversal convention of Fig. 1). By looking at Fig. 5 we obtain the following relations in the analysis part

$$Z_e^{old} = L(H'_{old})^t X_e^{old} + U(H'_{old})^t X_b^{new} \quad (4)$$

$$Y_b^{new} = L(G'_{new})^t X_e^{old} + U(G'_{new})^t X_b^{new} \quad (5)$$

The unknowns X_e^{old} and X_b^{new} are determined from the syn-

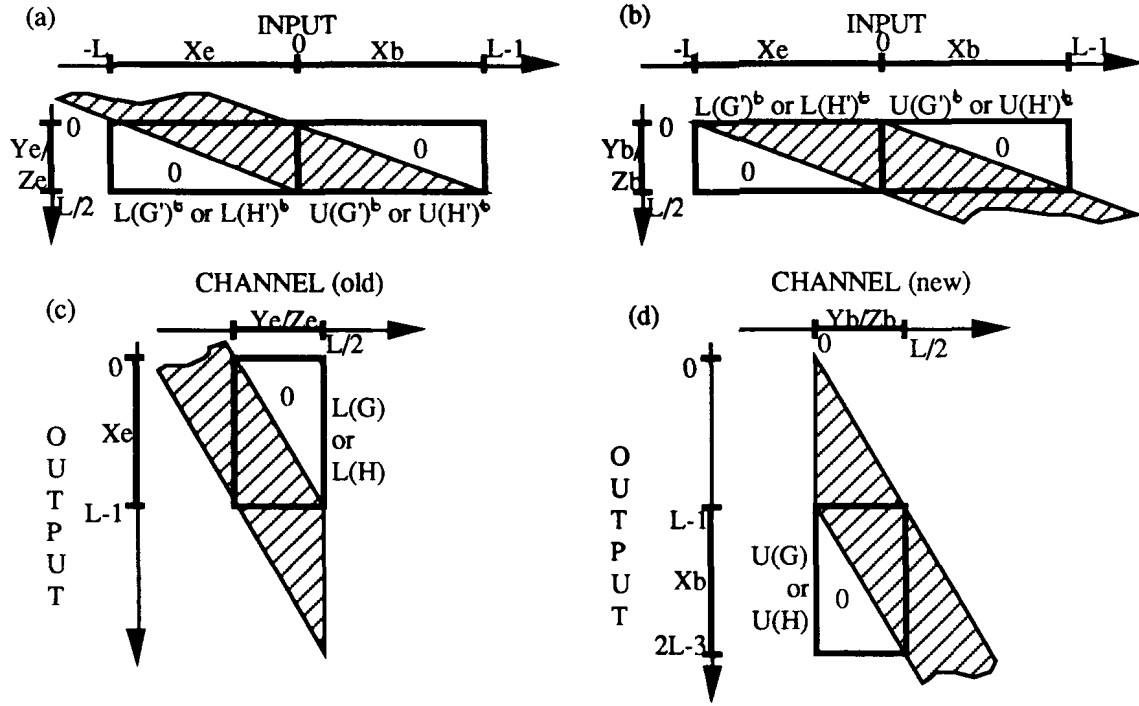

Figure 5. Schematic matrix description of the transition during analysis (a), (b) and synthesis (c), (d), for the "old" filter bank (a),(c) and the "new" one (b), (d).

thesis equations

$$X_e^{old} = L(G_{old})Y_e^{old} + L(H_{old})Z_e^{old} + \text{known terms} \quad (6)$$

$$X_b^{new} = U(G_{new})Y_b^{new} + U(H_{new})Z_b^{new} + \text{known terms} \quad (7)$$

where the "known terms" depend on transmitted samples of subband signals. Substituting (6), (7) into (4), (5) gives L linear equations for the L unknown samples in Z_e^{old} , Y_b^{new} .

$$(I - L(H'_{old})^t L(H_{old}))Z_e^{old} - U(H'_{old})^t U(G_{new})Y_b^{new} = c \quad (8)$$

$$(I - U(G'_{new})^t U(G_{new}))Y_b^{new} - L(G'_{new})^t L(H_{old})X_e^{old} = c' \quad (9)$$

where c and c' are known constants. In general, the matrix of this linear system is full-rank and (8), (9) can be solved for Z_e^{old} and Y_b^{new} , hence the input signal is reconstructed exactly at the transition.

6. CONCLUSION

In this paper, a delayed truncation method was presented which solves some problems arising when a finite-length signal is processed by a perfect reconstruction FIR filter bank. Instead of changing the filters at the borders in order to keep the exact reconstruction property without increasing the throughput, we discard the redundant information (i.e., additional samples generated by the transients of the filtering process), and recover it at the reconstruction.

This method has been applied in various situations. Two points should be emphasized:

First, the difference between the various types of boundary extension are not in the amount of reconstruction error, since our approach always leads to exact reconstruction. However, various extensions will result in signals more or less difficult to encode.

Second, the perfect reconstruction property is valid only if no quantization error occurs in the subbands, which is not

realistic. In actual situations, the recovered samples will include some errors, since they are recovered from quantized values. The methods presented here have various sensitivities to this problem. Our simulations show that this was never a great problem in actual compression schemes.

REFERENCES

- [1] J. L. Arrowood Jr. and M. J. T. Smith, "Exact reconstruction analysis/synthesis filter banks with time-varying filters," in Proc. ICASSP'93, vol. III, pp. 233-236.
- [2] F. Déprez, "Récupération de transitoires aux bords. Bancs de filtres variables dans le temps," Tech. report, SUPELEC, 1993.
- [3] C. Herley, J. Kovačević, K. Ramchandran and M. Vetterli, "Tilings of the time-frequency plane: Construction of arbitrary orthogonal bases and fast tiling algorithms," *IEEE Trans. Signal Processing*, Dec. 1993.
- [4] G. Karlsson and M. Vetterli, "Extension of finite-length signals for subband coding," *Signal Processing*, vol. 17, pp. 161-168, 1989.
- [5] K. Nayebi, T. P. Barnwell III, M. J. T. Smith, "Analysis-synthesis systems with time-varying filter bank structures," in Proc. ICASSP'92, vol. IV, pp. 617-620.
- [6] R. L. de Queiroz, "Subband processing of finite length signals without border distortions," in Proc. ICASSP'92, vol. IV, pp. 613-616.
- [7] I. Sodagar, K. Nayebi, T. P. Barnwell III, "A class of time-varying wavelet transforms," in Proc. ICASSP'93, vol. III, pp. 201-204.