



HAL
open science

Rényi Entropy Estimation for Secure Silicon Fingerprints

Alexander Schaub, Olivier Rioul, Sylvain Guilley, Jean-Luc Danger, Joseph J Boutros

► **To cite this version:**

Alexander Schaub, Olivier Rioul, Sylvain Guilley, Jean-Luc Danger, Joseph J Boutros. Rényi Entropy Estimation for Secure Silicon Fingerprints. IEEE Information Theory and Applications Workshop (ITA 2020), Feb 2020, Sans Diego, United States. , 2020. hal-02950211

HAL Id: hal-02950211

<https://telecom-paris.hal.science/hal-02950211>

Submitted on 27 Sep 2020

HAL is a multi-disciplinary open access archive for the deposit and dissemination of scientific research documents, whether they are published or not. The documents may come from teaching and research institutions in France or abroad, or from public or private research centers.

L'archive ouverte pluridisciplinaire **HAL**, est destinée au dépôt et à la diffusion de documents scientifiques de niveau recherche, publiés ou non, émanant des établissements d'enseignement et de recherche français ou étrangers, des laboratoires publics ou privés.

Rényi Entropy Estimation for Secure Silicon Fingerprints

Alexander Schaub¹, Olivier Rioul¹, Sylvain Guilley^{1,2}, Jean-Luc Danger^{1,2} & Joseph J. Boutros³

¹ LTCI, Télécom Paris, Institut Polytechnique de Paris, France, ² Secure-IC S.A.S., France, ³ Texas A&M University at Qatar, Doha, Qatar

Physically Unclonable Function (PUF)

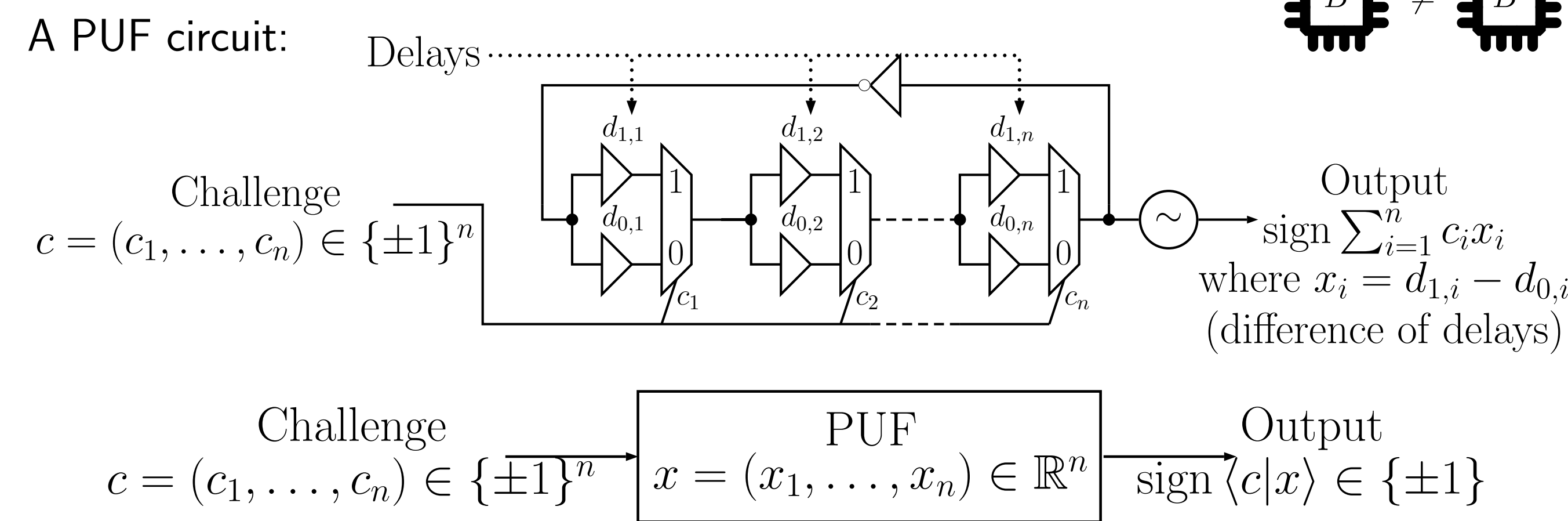

The PUF parameter x is **uncontrollable**: it depends on the manufacturing process and varies from one circuit to another ("static randomness").

x : outcome of an **i.i.d random vector** $X = (X_1, \dots, X_n)$ where $X_i \sim -X_i$.

The PUF behavior depends on a **challenge code**

$$\mathcal{C} = \{c^1, \dots, c^M\}$$

that defines the PUF output (**silicon fingerprint**)

$$B = (B_1, \dots, B_M) \text{ where } B_j = \text{sign} \langle c^j | X \rangle.$$

Motivation

Given a PUF design:

- How much **randomness** can be extracted from it? More precisely:
- How **unique** is the generated identifier (collision resistance)?
- Can a PUF be used to generate a (say) 128-bit **cryptographic key**?
- How difficult is it to **predict** the PUF response (using machine learning, e.g., SVM)?

Rényi Entropy as a PUF Security Metric

α -Entropy

$$H_\alpha(B) = \frac{1}{1-\alpha} \sum_{b \in \{\pm 1\}^M} P_B(b)^\alpha$$

Definition	Name	Significance
$H_0(B) = \log \#\text{Supp}(B)$	max-entropy	Number of PUFs
$H_1(B) = H(B)$	Shannon entropy	Probabilistic uncertainty
$H_2(B) = -\log \mathbb{P}(B = B'),$ $B \perp\!\!\!\perp B'$	Collision entropy	Resistance to random collisions
$H_\infty(B) = -\log \max_b P_B(b)$	min-entropy	Brute-force resistance

- $H_\alpha(B_1, \dots, B_M)$ **increases** with M (when adding new challenges to \mathcal{C}).
- $\max_{\mathcal{C}} H_\alpha(B) = H_\alpha(n)$ is attained for $M = 2^n$ (all possible challenges).

BTF Theory and Chow Parameters

A PUF with $M = 2^n$ is identified to a

Boolean Threshold Function (BTF)

$$f_x : c \in \{\pm 1\}^n \mapsto \text{sign} \langle c | x \rangle \text{ for a fixed } x \in \mathbb{R}^n.$$

Chow parameters of a BTF

$$\hat{f}_x = \sum_{f_x(c)=1} c \text{ (componentwise).}$$

They **uniquely identify** a boolean threshold function: $\hat{f}_x = \hat{f}_y \implies f_x = f_y$.

Result on the max-entropy

There are at most 2^{n^2} distinct Chow parameters. Hence $H_0(n) < n^2$ ($\forall n \geq 2$).

Invariance Under the Signed Permutation Group

Changing the **order** or **signs** of the X_i 's does not change P_B .

Signed Permutation Group:

$G_n = S_n \times \{\pm 1\}^n$ acts on \mathbb{R}^n :

$$(g \cdot x)_i = s_i x_{\sigma(i)} \text{ where } g = (\sigma, s) \in S_n \times \{\pm 1\}^n.$$

Results on equal probabilities

- The action of G_n preserves probabilities: $\mathbb{P}(f_X = f_x) = \mathbb{P}(f_X = f_{g \cdot x})$
- Hence all PUFs in $\text{Orb}(f_x) = \{f_{g \cdot x} \mid g \in G_n\}$ have the same probability.

Results on the orbit size

- The action of G_n preserves Chow parameters: $\hat{f}_{g \cdot x} = g \cdot \hat{f}_x$
- Hence, using the orbit-stabilizer theorem on $\text{Orb}(f_x)$,

$$\#\text{Orb}(f_x) = \frac{2^n n!}{2^{m_{\hat{f}_x}(0)} \prod_{k \in \mathbb{N}} m_{\hat{f}_x}(k)!} \text{ where } m_{\hat{f}_x}(k) = \#\{i : (\hat{f}_x)_i = \pm k\}.$$

Estimating the PUF Distribution

for $i \leftarrow 1$ to N do

Generate n realizations $x = (x_1, \dots, x_n)$;
Take $x \leftarrow |x|$ and sort x to get the orbit leader;
Compute Chow parameters \hat{f}_x ;
Set **count** $[\hat{f}_x] \leftarrow$ **count** $[\hat{f}_x] + 1$;

end

for $c \in$ **count** do

$$\text{orbit_size}[c] \leftarrow \frac{2^n n!}{2^{m_c(0)} \prod_{k \in \mathbb{N}} m_c(k)!}, \quad \text{proba}[c] \leftarrow \frac{\text{count}[c]}{N * \text{orbit_size}[c]};$$

end

Simulation interpretation

For any orbit leader f_x , there are **orbit_size** $[\hat{f}_x]$ probabilities equal to **proba** $[\hat{f}_x]$.

Simulation Results for Gaussian X

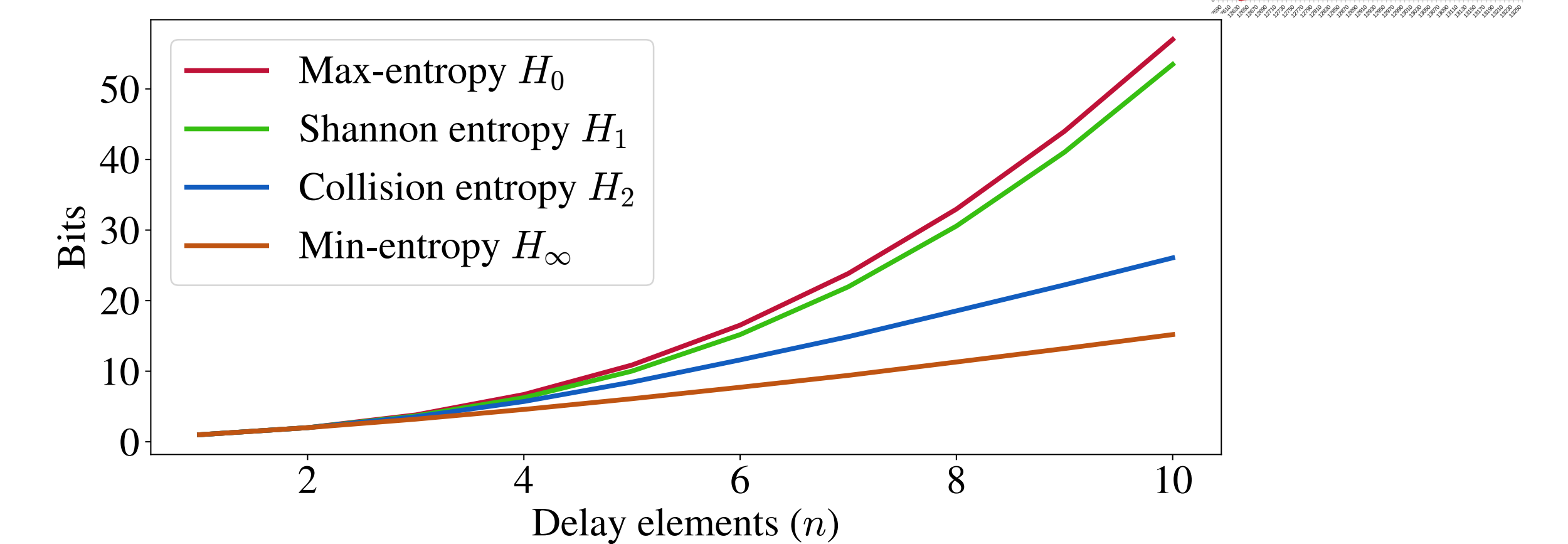

Results with 95 % confidence level

n	Sample size	$H_1(n)$ (bits)	$H_2(n)$ (bits)	$H_\infty(n)$ (bits)
3	N/A	3.6655...	3.5462...	3.2086...
4	N/A	6.2516...	5.7105...	4.5850...
5	10^{10}	$10.014 \pm 1 \cdot 10^{-3}$	$8.4559 \pm 8 \cdot 10^{-4}$	$6.1007 \pm 1 \cdot 10^{-4}$
6	10^{10}	$15.191 \pm 1 \cdot 10^{-3}$	$11.600 \pm 2 \cdot 10^{-3}$	$7.7353 \pm 1 \cdot 10^{-4}$
7	10^{10}	$21.987 \pm 1 \cdot 10^{-3}$	$14.890 \pm 8 \cdot 10^{-3}$	$9.4733 \pm 2 \cdot 10^{-4}$
8	$2 \cdot 10^{10}$	$30.5636 \pm 8 \cdot 10^{-4}$	$18.55 \pm 3 \cdot 10^{-2}$	$11.3022 \pm 2 \cdot 10^{-4}$
9	$2 \cdot 10^{10}$	$41.0376 \pm 8 \cdot 10^{-4}$	$22.2 \pm 2 \cdot 10^{-1}$	$13.2127 \pm 4 \cdot 10^{-4}$
10	$3 \cdot 10^{12}$	$53.4738 \pm 1 \cdot 10^{-4}$	$26.1 \pm 1 \cdot 10^{-1}$	$15.1900 \pm 1 \cdot 10^{-4}$

Conclusion and Perspectives

Cryptographic applications require a source of high entropy.

We show how to calibrate PUFs to achieve a given security level:

- Our simulation results suggest that $H_1(n) \approx n^2$ (much greater than n)!
- Exact computation of entropies for higher values of n becomes intractable.
- But in practice, only a subset of all possible challenges is chosen:
How should we select them to maximize entropy?

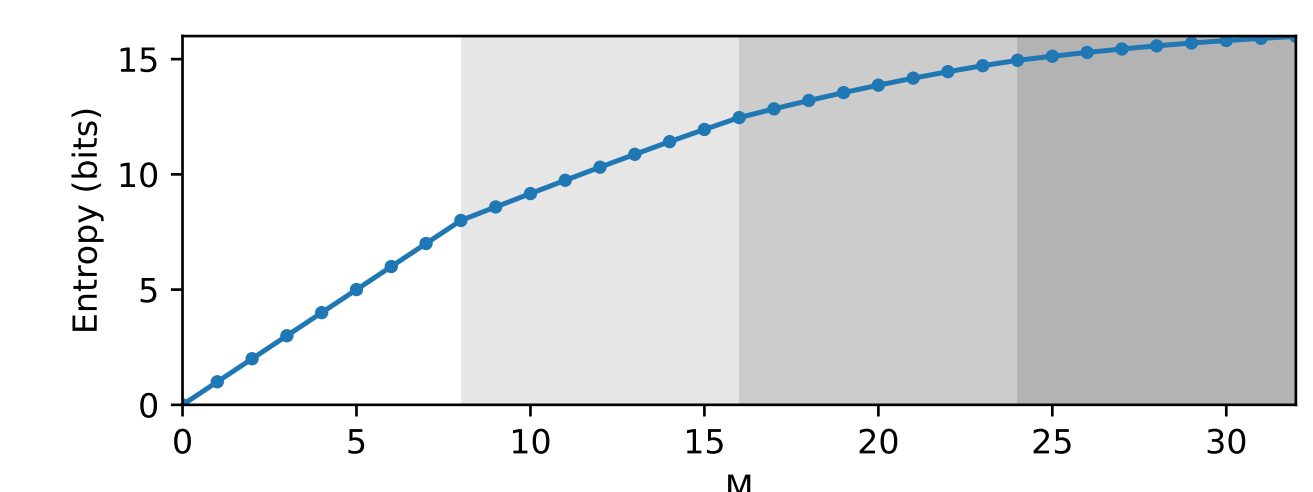

References

- [1] Sze-Tsen Hu. *Threshold Logic*. Univ of California Press, 1965.
- [2] Olivier Rioul, Patrick Solé, Sylvain Guilley, and Jean-Luc Danger. "On the entropy of physically unclonable functions". In: *ISIT*. 2016, pp. 2928–2932.
- [3] Alexander Schaub, Jean-Luc Danger, Sylvain Guilley, and Olivier Rioul. "An improved analysis of reliability and entropy for delay PUFs". In: *Proc. of Euromicro DSD 2018, Prague*.
- [4] Alexander Schaub, Olivier Rioul, and Joseph J. Boutros. "Entropy estimation of physically unclonable functions via Chow parameters". In: *57th IEEE Allerton Conference*. 2019, pp. 698–704.
- [5] Alexander Schaub, Olivier Rioul, Jean-Luc Danger, Sylvain Guilley, and Joseph J. Boutros. "Challenge codes for physically unclonable functions with Gaussian delays: A maximum entropy problem". In: *Advances in Mathematics of Communications* (2019).